



publications engineering

SERVICE BULLETIN

COLLINS RADIO COMPANY

Cedar Rapids, Iowa 52406

REVISION NO. 1
TO
PM-2 SERVICE BULLETIN NO. 1

Attached is a revised copy of PM-2 Service Bulletin No. 1 titled "Extension of Design Specifications for Input Voltage Limits," originally dated 17 April 1963.

This revised issue replaces the original publication in its entirety. The reasons for this revision are as follows:

1. To change to a slightly longer standoff post than the one listed in the original modification kit.
2. To add a reference to the new edition of the PM-2 instruction sheet.
3. Add new illustration (figure 5, original figure 5 is changed to figure 6).

Black lines in the left-hand margin indicate where changes have been made to the original issue.

April 17/63
1-Jan 3/69



COMMUNICATIONS
PM-2 LIGHTWEIGHT AC POWER SUPPLY FOR KWM-2/2A TRANSCEIVER
SERVICE BULLETIN NO. 1
EXTENSION OF DESIGN SPECIFICATIONS FOR INPUT VOLTAGE LIMITS

This modification extends the design specifications for input voltage limits. This modification is not intended to allow continuous operation at higher voltages, but to allow operation under wider fluctuations of line voltage such as those encountered in military installations having poorly regulated primary power sources. This modification will allow momentary primary surges up to 150 volts without subjecting components to breakdown.

This modification is recommended for installations which have experienced difficulties in line voltage regulation. To determine if modification is installed, remove dust cover. If there are two 100-uf capacitors under the speaker, this change has been made; if not, this change has not been made.

The estimated time required to perform this modification is 3 1/2 hours.

Edition no. 8 of the PM-2 Lightweight AC Power Supply Instruction Sheet, Collins part number 523-0074000, dated 1 October 1968, includes the changes covered by this service bulletin.

For modification parts, price quotations (minimum order charge is \$15.00), and availability contact Collins Radio Company, Service Parts Department, Cedar Rapids, Iowa 52406. All parts orders must specify the Collins modification kit number, or part numbers, quantity required, and reference this service bulletin.



MODIFICATION PROCEDURE

1. Remove PM-2 cover by removing two screws fastening it to unit.
2. Remove eight screws holding speaker and standoffs in place. Lay speaker aside.
3. Remove four screws holding terminal board TB1 in place and carefully swing board away from chassis.
4. Drill the three holes in chassis as shown in figure 1.
5. Fasten the four clips (139-3171-00) in place with two machine screws (343-0132-00) and nuts (313-0043-00) as shown in figures 2 and 3. Insert the screws in the two smaller new holes with a clip on each side of the chassis.
6. Insert rubber grommet (201-1040-00) in the larger of the three newly drilled holes.
7. Add 4-lug terminal strip TB4 (306-0698-00) on the bottom side of the chassis securing with rear mounting screw of transformer T1 that is nearest speaker. See figure 3. The hole in the mounting tab may have to be enlarged slightly to allow insertion of the mounting screw.
8. Add 3-lug terminal strip TB5 (306-0587-00) on the bottom side of the chassis securing with front mounting screw of speaker that is nearest outside of chassis. See figure 3.
9. Add 3-lug terminal strip TB3 (306-0001-00) on top side of chassis using same screw with which TB5 is mounted. Add new standoff (779-2951-001) to this screw.
10. Add 3-lug terminal strip TB2 (306-0587-00) on top side of chassis using other front mounting screw of speaker. Add new standoff (779-2951-001) to this screw.
11. Snap the four capacitors C1, C2, C3, and C4 (183-1576-00) in the four newly installed clips.
12. Replace the remaining two standoffs to which the speaker is mounted with new standoffs (779-2951-001).
13. Add 270K resistors R3, R4, R10, R11 (745-3454-00) as shown in figures 2 and 3.
14. Remove and discard 20-uf capacitors C1, C2, C3, and C4 located on back side of terminal board TB1.
15. Remove and discard old 470K resistors R3 and R4 located on front side of terminal board TB1.
16. Remove bus wire connected between terminals 10 and 14 on TB1. See figures 4 and 5 for TB1 terminal designations.
17. Remove bus wire with black sleeving connected between terminals 5 and 15 on TB1.
18. Disconnect white-red wire from terminal 14 on TB1 and connect to terminal 10 on TB1.



19. Disconnect brown wire from terminal 5 on TB1 and connect to terminal 2 of TB4. See figures 3, 4, and 5.
20. Add white-black-blue wire (439-1810-00) from terminal 10 on TB1 to terminal 3 of TB4.
21. Add no. 20 AWG wire (421-2020-00) with sleeving (152-1351-00) from terminal 2 of TB5 to terminal 4 of TB4.
22. Add no. 20 AWG wire (421-2020-00) with sleeving (152-1351-00) from terminal 1 of TB5 to terminal 4 of TB4.
23. Sleeve with insulation (152-1351-00) the leads of the four newly installed capacitors and connect as shown in figures 2 and 3. CHECK POLARITY MARKINGS.
24. Add no. 20 AWG bus wire (421-2020-00) sleeved with insulation (152-1351-00) from terminal 3 of TB2 to terminal 2 of TB3.
25. Add no. 20 AWG bus wire (421-2020-00) sleeved with insulation (152-1351-00) from terminal 3 of TB2 through rubber grommet to terminal 2 of TB4.
26. Replace power supply terminal board TB1 and four screws to place from which removed in step 3.
27. Replace speaker and four screws to places from which removed in step 2.
28. Replace cover and two screws removed in step 1.

PARTS REQUIRED

Modification kit 554-5219-00 consisting of the following items is required to modify one PM-2 unit.

<u>NEW COLLINS PART NUMBER</u>	<u>QTY</u>	<u>DESCRIPTION</u>
183-1576-000	4	Capacitor, 100 uf 350 wvdc, C1, C2, C3, C4
139-3171-000	4	Clip, capacitor retaining
201-1040-000	1	Grommet, rubber
306-0001-000	1	Terminal strip, 3-lug TB3
306-0587-000	2	Terminal strip, 3-lug TB2, TB5
306-0698-000	1	Terminal strip, 4-lug TB4
343-0132-000	2	Screw, machine, 3/16
313-0043-000	2	Nut
779-2951-001	4	Standoff, post, 3 1/8 - inch
745-3454-000	4	Resistor, 270K, 1-watt
421-2020-000	2 (ft)	Wire, no. 20 AWG, bare bus
152-1351-000	4 (ft)	Sleeving, insulation
439-1810-000	0.8 (ft)	Wire, no. 20 AWG, white-black-blue MIL-W-16878 Type C insulation

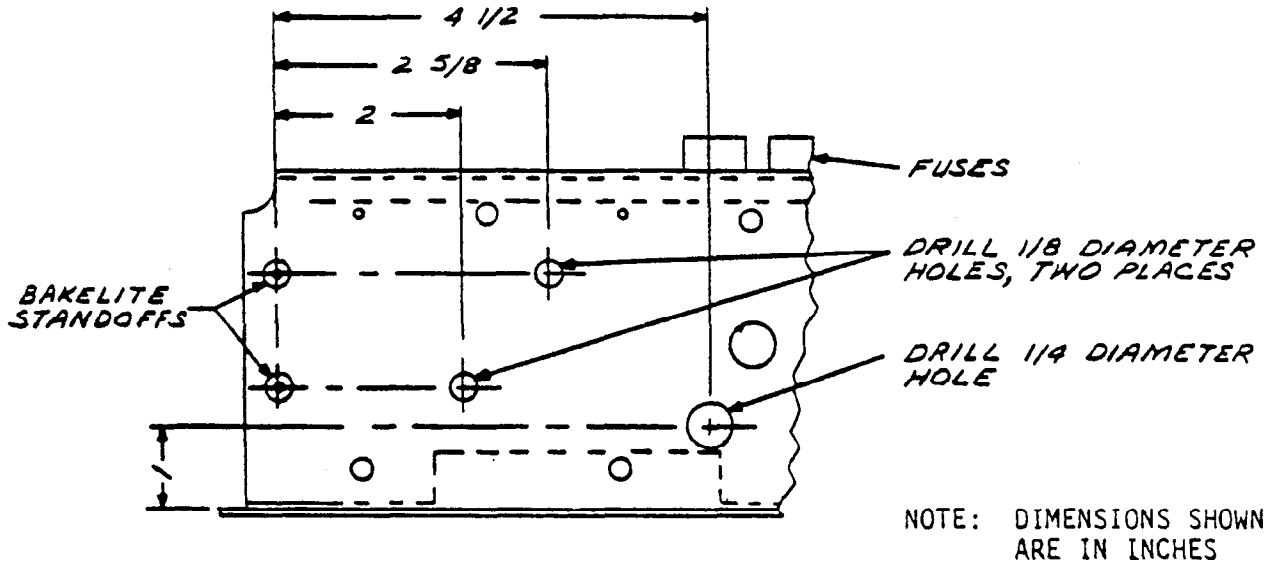

PM-2 Chassis Frame With TB1 Removed, Partial Bottom View
Figure 1

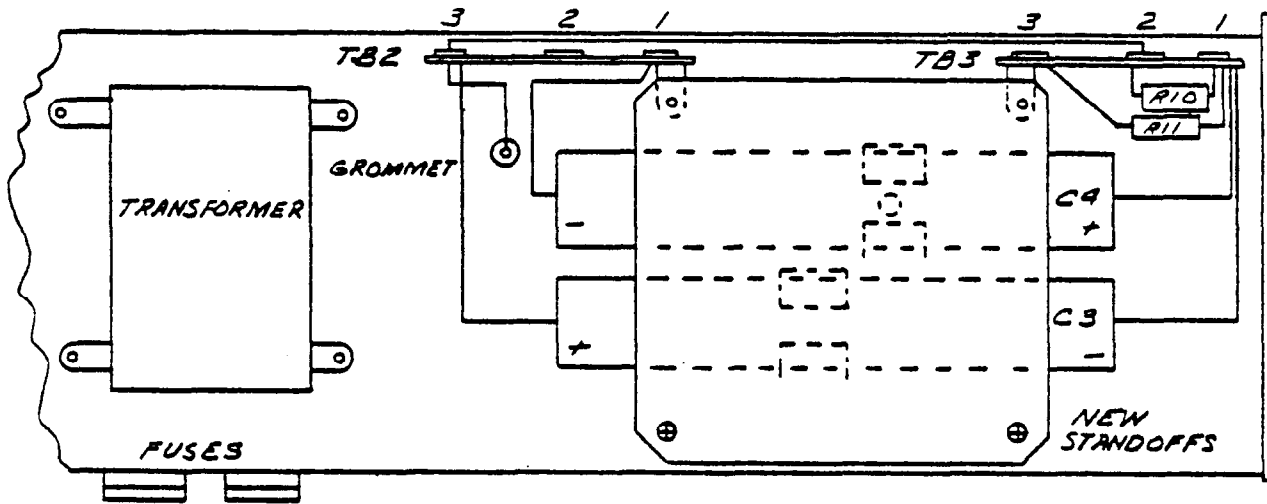

PM-2, Partial Top View
Figure 2

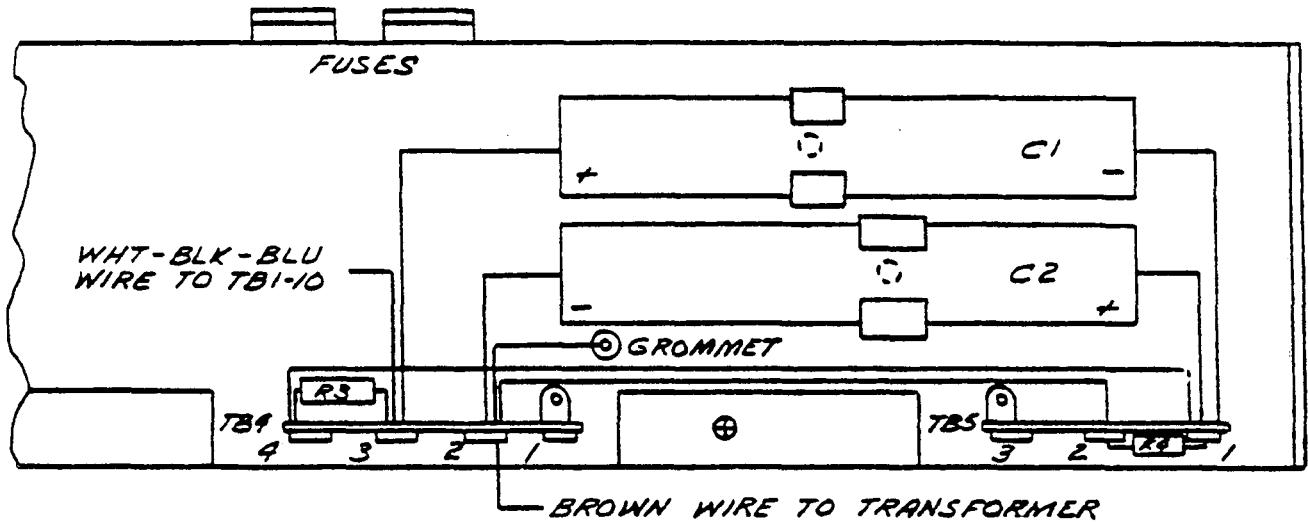

PM-2 With TB1 in Place, Partial Bottom View
Figure 3

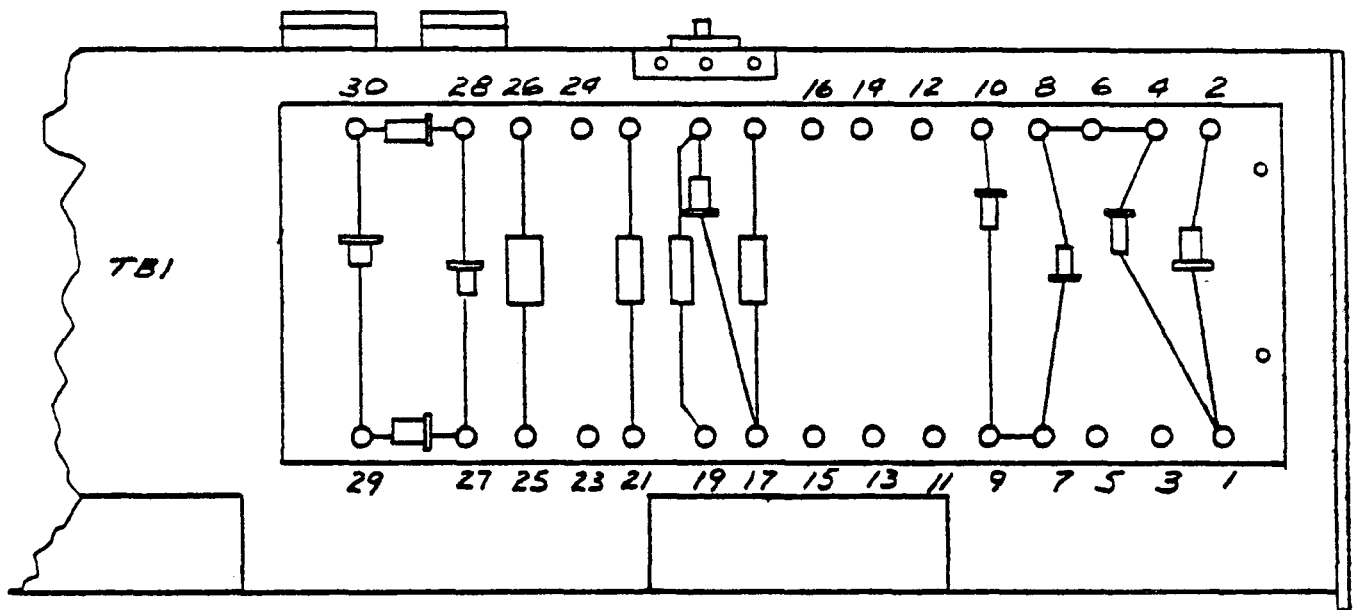

PM-2 With TB1 in Place, Partial Bottom View
Figure 4

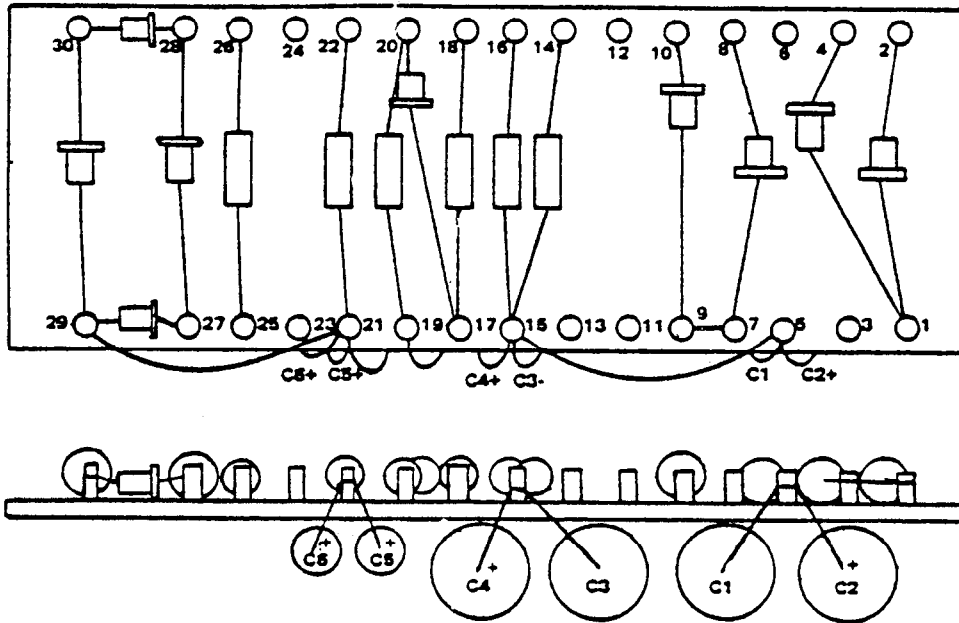

OLD TB1 SUBASSEMBLY BEFORE MODIFICATION

PM-2 TB1 Partial Bottom and Edge View
Figure 5

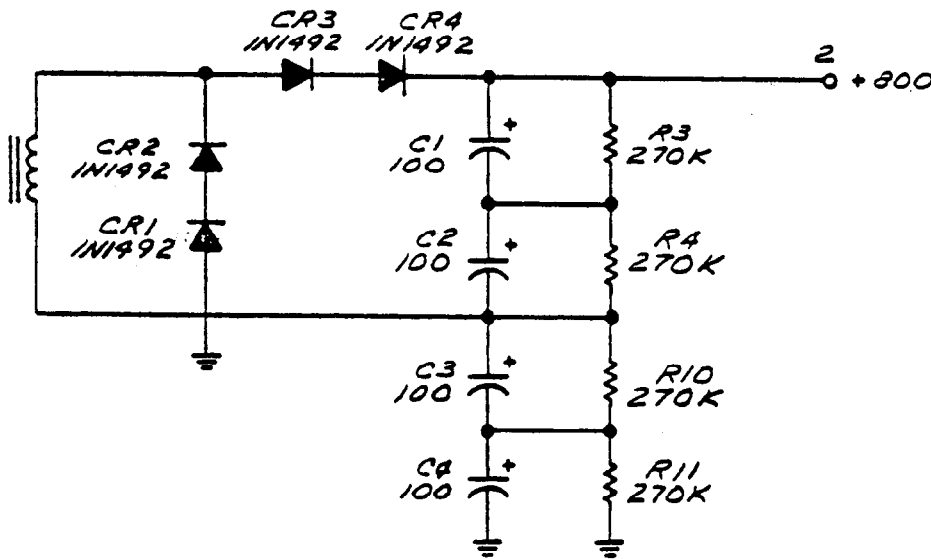

AFTER MODIFICATION

PM-2 High Voltage Circuit, Schematic Diagram
Figure 6